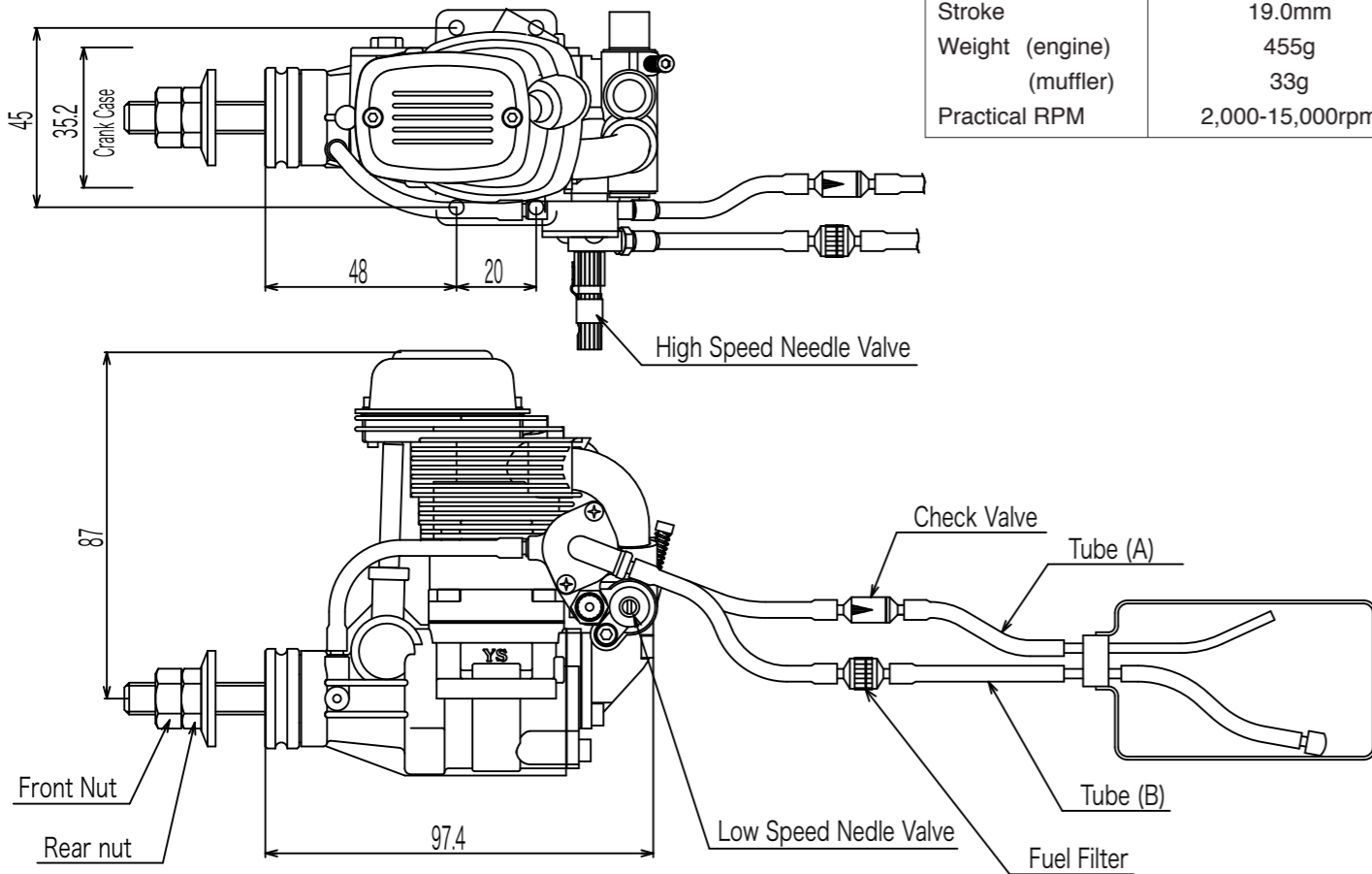

Fig.1



FEATURES

The FZ70S is the most powerful 4 cycle engine of its size and was developed for sport flying as well as power demanding acrobatics.

- Supercharged system
- Fuel injected
- Regulated and pressurized fuel system
- Muffler

The pressurized fuel and injection system makes throttle response superior and is unaffected by tank level.

GLOW PLUG

Select the most appropriate plug from those designed specifically for 4 cycle engines. Glow plug selection greatly affects the maximum engine output and low idle. We recommend the YS #4.

INSTALLATION

1. Connect the engine to the tank as shown in fig.1. Since high pressure is applied to the tank, tighten all connections carefully. Care must be taken to prevent pressure leakage due to under tightening of the check valve or by kinking the fuel lines.
2. Always use a fuel filter. We recommend the YS fuel filter.
3. Match the direction of the check valve arrow fig.1 with the arrow facing to wards the tank.

PROPELLER INSTALLATION

Due to the high torque of the FZ70S engine, we have equipped it with a double lock system for safety.

1. Mount the propeller and tighten the rear nut. Next, tighten the front nut as shown in Fig.1.
2. Select a good quality propeller that will turn in the 9,000 to 12,000 rpm range. We recommend sizes 12x8, 13x7.

START UP

1. Remove tube B from the filter: remove tube A from the check valve, then fill the tank. (CAUTION: If tank is filled or under pressure remove tube A first, then tube B. Fuel will eject if tube B is removed while the tank is pressurized.)
2. Open the needle valve 2 turns from the fully closed position.
3. Open the throttle about 10% from the idle position (not fully). And turn the propeller 10 times. This primes sending fuel to the carburetor.
4. Close the throttle to the idle position and connect the glow plug battery. The engine is now ready for starting.

DO NOT ATTEMPT TO START FULL THROTTLE, AS THIS IS VERY DANGEROUS.

BREAK IN

To maximize engine performance and increase durability, please follow this break-in procedure:

1. Use the same size (or slightly smaller) propeller than you intend to use in flying.
2. Use a good quality fuel which contains 15-30% nitromethane and oil content of 20-24%. Synthetic or castor oil can be used, or a combination of synthetic and castor. Do not use four cycle fuel due to low oil content.
3. The needle valve should be set so that the engine is running at a rich setting. Run the engine approximately 20 minutes with this setting.
4. Mount the engine to the model and fly ten times with this setting. This concludes the break-in procedure, it is advisable to always use a slightly rich setting to keep the moving parts lubricated, even after the break-in period .

HIGH SPEED ADJUSTMENT

1. Adjustment of high speed is done by the carburetor needle valve. When the needle valve is turned clockwise, the mixture is leaner. When it is turned counterclockwise, the mixture is richer. A good starting position for the high speed needle valve is 2 turns open from the fully closed position.
2. When the engine is started, open the throttle gradually. Next, find the peak position (highest RPM) by adjusting the needle valve. Then the needle valve should be opened approximately 1/8 of a turn from full RPM to achieve best performance. The engine may stop if the throttle is opened to full immediately after starting. Wait until the engine temperature rises and then open the throttle slowly .
3. For flying, it is advisable to use a slightly richer mixture setting. By using a richer mixture, the engine temperature is maintained and RPM stability improves.

LOW SPEED ADJUSTMENT

This engine is equipped with a new low speed needle valve to adjust the mixture from low to mid throttle. This needle valve is located on the side of the throttle barrel opposite the throttle arm (Fig.1).

1. Open the low speed needle to 1 turns from fully closed position.
2. The low speed needle valve should be set after the high speed needle valve has been adjusted. Close the throttle gradually to a idle (approximately 2500rpm). Let it idle for 20 to 30 seconds and then slowly advance the throttle. The adjustment is satisfactory at low speed if transition is smooth at this time.
3. If the engine is running rough on idle, the low speed mixture is rich. If the engine starts to speed up and dies on idle or starts to detonate, when advancing the throttle, the mixture is lean. Turn the low speed needle valve clockwise to richen and counterclockwise for a leaner mixture (note that the direction of the low speed needle valve is opposite the high speed needle valve). Adjustments to the low speed needle valve should be 1/8 to 1/4 of a turn increment at a time to achieve smooth throttle response.

IMPORTANT!

The regulator adjusting screw on this engine is factory set. No further adjustments are necessary. If for some reason you have to disassemble the regulator assembly, the regulator adjusting screw should be set flush with the regulator body.

TAPPET CLEARANCE ADJUSTMENT

1. Tappet clearance is factory preset. No adjustment is necessary until after 1 hour of operation (including break-in period).
2. Clearance adjustment should be done when the engine is cool. When the engine temperature is high, clearance is higher due to thermal expansion.
3. The proper clearance setting should be at 0 - 0.1mm. The adjustment is achieved by loosening the locknut (fig.2) and turning the adjusting screw. Tighten the locknut after the adjustment is achieved. After the initial 1 hour adjustment, this procedure should be performed a few every 2 hours of use.

Fig.2

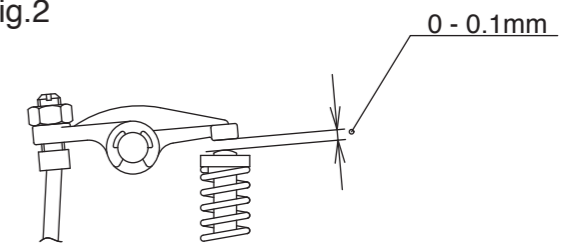

CAM GEAR TIMING ADJUSTMENT

If for some reason you have to disassemble your engine, please follow these important steps on reassembling the cam gear.

1. Remove the carburetor and backplate assembly. Notice the impression made on the crankshaft counterweight. Position it directly straight down or in line with the case outer seam line.
2. When reinstalling the cam gear, the side with a point mark should be facing the opening of the gear box. Note that it should also be mounted with the point mark located towards the top of the engine just below the cam followers.

DIAPHRAGM AND CHECK VALVE DISASSEMBLY

Diaphragm

1. Remove the adjustment screw of the valve, and then remove the inside valve and spring.
2. Clean the inside with alcohol or appropriate cleaner. Reassemble.
3. Screw in the regulator screw until flush with the diaphragm body.

Check valve

1. Open the valve by rotating the body counterclockwise.
2. Reassemble the check valve carefully.

IMPORTANT!

Silicone rubber is used in many parts of the YS engine. Use only glow fuel or methanol for cleaning. Gasoline and other volatile solutions will damage the silicone if used.

NO.	PARTS#	DESCRIPTION	QTY
1	YS6270	Crankcase	1
	YS6275	Cylinder head assembly	
2	YS6280	Cylinder head	1
3	YS2810	Intake valve	1
4	YS2815	Exhaust valve	1
5	YS2820	Valve spring set	2
6	YS2030	Spring retainer set	2
7	YS2040	Valve spring clips	4
8	YS5015	Cylinder head gasket	1
9	YS2840	Head bolt set	4
10	YS2845	Valve cover	1
11	YS2850	Valve cover gasket	1
12	YS2855	Valve cover screws	2
13	YS2860	Intake pipe	1
14	YS2865	Intake pipe O rings	2
15	YS6285	Crankshaft	1
16	YS6290	Crankshaft ring	1
17	YS6295	Rear bearing	1
18	YS2880	Front bearing	1
19	YS2885	Front bearing seal	1
20	YS2890	Drive washer	1
21	YS2895	Drive washer retainer	1
22	YS0825	Prop washer	1
23	YS6145	Prop nut set	2
24	YS6300	Piston	1
25	YS6305	Piston ring	1
26	YS4395	Wrist pin	1
27	YS6307	Wrist pin retainers	2
28	YS2930	Rocker arm set	2
29	YS0560	Valve adjuster set	2
30	YS0565	Adjuster nut set	2
31	YS2935	Rocker arm set	1
32	YS2940	Rocker arm screw	1
33	YS0580	E ring clip set	2
34	YS2945	Cam	1
35	YS2950	Cam cover	1
36	YS2955	Cam cover O ring	1
37	YS4400	Cam cover screws	2
38	YS2960	Cam bearing set	2
39	YS2965	Cam follower set	2
40	YS2970	Push rod set	2
41	YS6400	Push rod cover set	2
42	YS2980	Push rod cover O rings	4
43	YS6365	Con rod	1
	YS6370	Back plate assembly	
44	YS6375	Back plate	1
45	YS6380	Disc valve	1
46	YS6385	Disc valve pin	1
47	YS6390	Disc valve set screw	1
48	YS3005	Back plate gasket	1
49	YS3010	Back plate screws	2
50	YS6315	Carburetor body	1
51	YS6320	Throttle barrel	1
52	YS3025	Throttle barrel O ring	1
53	YS1090	Throttle barrel retainer	1
54	YS0200	Throttle arm set	1
55	YS0785	Throttle stop screw	1
56	YS0790	Throttle stop spring	1
	YS6395	Needle valve set	
57	YS3030	Needle valve	1
58	YS2695	Needle valve O ring	1
59	YS6325	Needle socket	1
60	YS6330	Needle socket O ring	2
61	YS2710	Needle detent	1
62	YS4010	Low speed needle	1
63	YS4015	Low speed needle O ring	1
64	YS3040	Carburetor gasket	1
65	YS3045	Carburetor screws	4
	YS6335	Regulator assembly	
66	YS5330	Regulator body A	1
67	YS5340	Diaphragm	1
68	YS5395	Regulator valve	1
69	YS5345	Regulator valve O ring	1
70	YS6340	Regulator body B	1
71	YS6345	Regulator set screws	2
72	YS6350	Regulator spacer	1
	YS3095	Muffler set	
73	YS3065	Muffler assembly	1
74	YS3070	Exhaust pipe	1
75	YS3075	Rock nuts	2
	YS0405	Check valve	1
	YS6355	Gasket set	3
	YS6360	O ring set	13

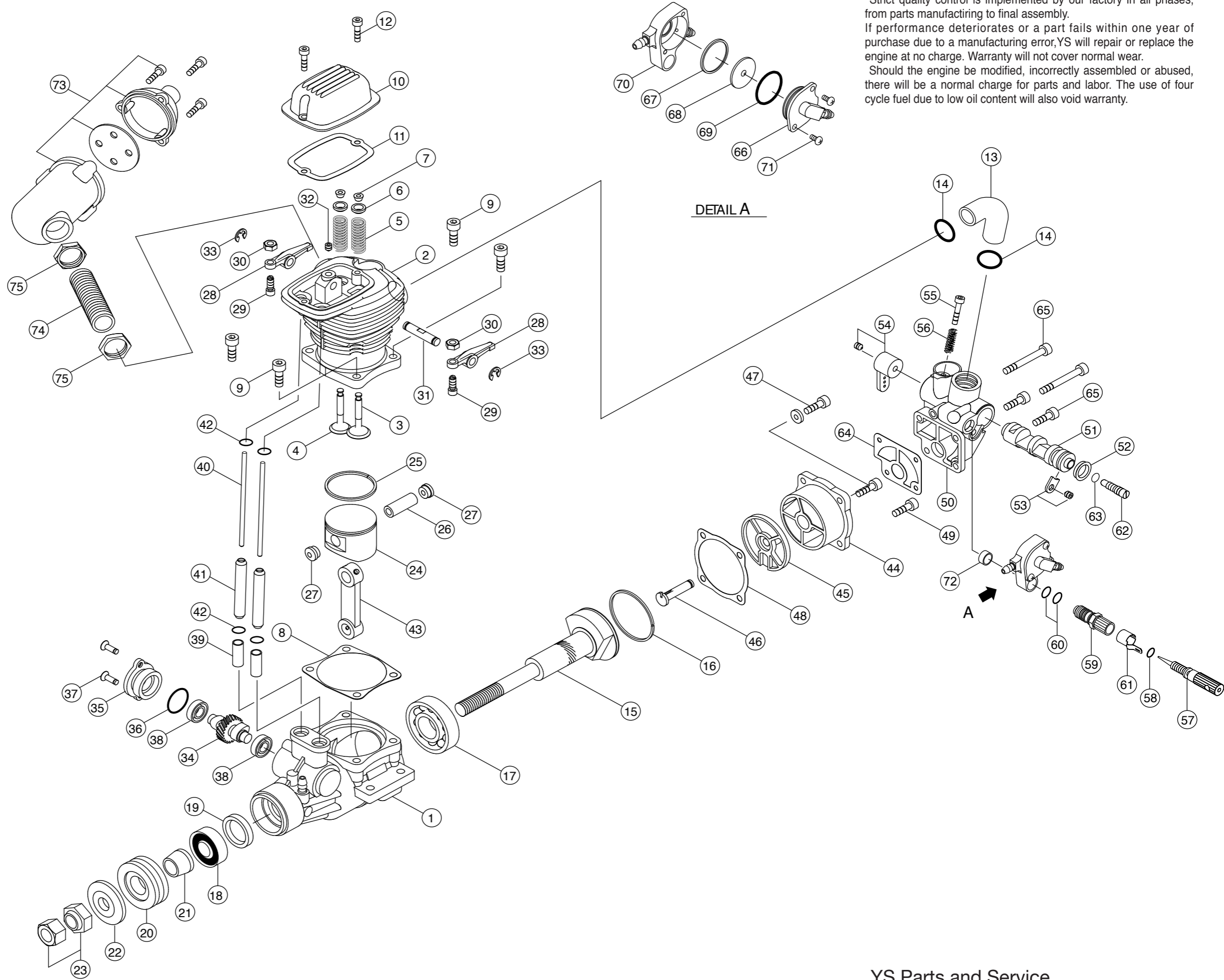

WARRANTY

Strict quality control is implemented by our factory in all phases, from parts manufacturing to final assembly. If performance deteriorates or a part fails within one year of purchase due to a manufacturing error, YS will repair or replace the engine at no charge. Warranty will not cover normal wear. Should the engine be modified, incorrectly assembled or abused, there will be a normal charge for parts and labor. The use of four cycle fuel due to low oil content will also void warranty.

YS Parts and Service
 1370 PORTER DRIVE MINDEN NEVADA 89423
 Phone: 775-267-9252 Fax: 775-267-9690