

## Safety Instructions

In order for you to use of the engine, please read through this instruction manual carefully. This instruction manual uses special words, if you have any difficulties for understanding, please ask the hobby shop you purchased or contact us directory.

1. Mount the propeller must use propeller nut supply with the engine.
2. Select a good quality propeller and follow instruction by manufactures.
3. Select a propeller size not increases practical rpm in the air.
4. Be sure not people standing front and sides of propeller while running.
5. Use electric starter to start the engine with idle position of the carburetor.
6. After start the engine, move behind of propeller and well adjust needle setting before you fly.
7. It becomes extreme high temperature while and after engine runs. Do not touch engine, exhaust header, muffler, and any parts attached to the engine while engine runs or before cool it down.
8. Ignition system develops extreme high voltage so please careful when you operate. It is very dangerous to modify the ignition systems by your self.
9. Sparking noise may cause shorten the range of receiver. Please range check with motor running on the ground before you fly. If there are range problem, DON'T FLY!
10. If engine runs not correctly, DON'T FLY!
11. Do not use this engine other than radio controlled airplanes. Can not use for radio controlled helicopters.
12. You have full responsibility while you operate the engine. Please be extra care for safety when never you operate the engine.

## Installation

Connect the engine to the tank and CDI wiring as shown in "Fig.1" Battery and switch for CDI unit is not supplied of the engine set. Soft mount and fuel filter are option.

1. The recommended fuel tank size is 500cc to 700cc (18 to 24 oz). A standard clunk type fuel tank may be used. If this type of tank is used, you must use the special clunk supplied with the engine. Please note that with this clunk, all of the fuel cannot be used from the tank. As soon as any part of the clunk becomes exposed, the engine will stop due to air entering the fuel pump.

2. Always use a fuel filter. We recommend YS filter (YS1195). With this filter, you must remove the cloth portion of the filter and leave both the metal filter screens in place.
3. Because of this pump system, fuel level of the tank will not influence of engine runs, you can place fuel tank near C.G. position.
4. Please consider avoid cutting ignition wires by vibration when you do wiring. Use plastic "spiral wrap" supplied the engine set to wrap the shielded plug wire.
5. Please place receiver and ignition box about 15cm apart. Some of the radio needs to be apart them over 30cm to avoid radio interference. Wrap the ignition box in form rubber or other vibration absorbing material, same manner of receiver, and fasten. Do not use bracket holes on the box for fasten directory to the airplane.

## Fuel

1. Use a good quality alcohol based model engine fuel containing 5% to 25% nitro, and oil content 5% to 25%. You can not use gasoline fuel.
2. When you filling the tank, disconnects Fuel Tube "A", or Fuel Tube "B" see "Fig.1" from connecting tube to filling. If you use "T" nipple on the fuel line to filling, use fuel stopper on the Fuel Tube "A" see "Fig.1" to avoid fuel in to the engine.

## Propeller

1. Due to the high output power of the DZ185CDI engine, it is supplied with a double locknut system for added safety. Mount the propeller and tighten the rear nut. Next, tighten the front nut. The rear nut has an offset shoulder so the front nut will secure itself to the rear nut.
2. Please retighten propeller nut periodically.
3. Select a propeller that will allow the engine to run at maximum speed between 6,000 to 8,000 rpm range.
4. We recommend sizes 20x10.5, 20.5x10, 21X10. Other prop sizes may be used as long as the correct rpm range.

## High Speed Needle Valve Adjustment

1. An electric starter is mandatory for starting this engine.

2. When the needle valve is turned clockwise, the mixture is leaner. When it is turned counter-clockwise, the mixture is richer. A good starting position for the high speed needle valve is 2 turns open from the fully closed position.
3. Check ignition switch off first and turn the engine by electric starter with full open throttle to get fuel from tank to carburetor.
4. Close the carburetor to the idle position, turn on ignition switch and start the engine by electric starter. Warm up the engine with little higher than idle rpm.
5. Brake-in the engine one or two tanks of fuel on the ground with good rich mixture setting before you adjust for best high speed needle position.
6. To achieve best high speed needle valve position by gradually turn needle valve clock wise till rpm drops with fully opened throttle. The position right before rpm becoming drops is the peek position ( highest RPM ). Then the needle valve should be opened approximately 1/4 turns from highest RPM.

## Brake-in

1. Starting the engine with high speed needle valve 2 turns open from the fully closed position and idle position on carburetor.
2. After start the engine, increases rpm gradually by operates throttle control up and down. Do not suddenly open throttle to fully open position.
3. If mixture is too rich and miss firing, turn clockwise high speed needle valve to leaner mixture.
4. Brake-in the engine one or two tanks (600cc or 20oz. tank) of fuel on the ground with richest possible mixture setting.

## Battery for CDI Unit

Use 4.8~8.4V Ni-Cd ,Ni-MH or Li-Po batteries capacity around 700mAh. You can get over 5 (five) 10 minutes flights.

## Idling adjustment

1. To get 1,200rpm to 2,000rpm idling.
2. When the regulator is turned counter-clockwise, the idle mixture is leaner. When the regulator is turned clockwise, the idle mixture is richer. Adjust regulator by turn 45 degree at a time.
3. If idle mixture is too rich, gradually rpm drops and stops after continuous idling. If engine stops when you change attitude of airplane on the ground also too rich on idle mixture. If mixture is too lean on idle, rpm is go up and down and not keep stable when you make continuous idle.

## Spark Plug

Use spark plug supply with the engine. Plug gap is 0.30mm (0.013") to 0.45mm (0.018"). If plug gap become over 0.5mm (0.020") will cause miss firing the engine. If gap becomes over 0.45mm, tap the element by hammer to adjust the gap of the plug.

## Tappets Adjustment

1. Tappet clearance is preset at the factory.
2. Clearance adjustment may need after first one hour running time due to initial wear. After first adjustment, clearance should be checked as normal maintenance for every 10 hours running for maintain maximum performance.
3. Clearance adjustment should be done when the engine is cool.
4. The proper clearance should be set at 0mm (0.000") to 0.1mm (0.004"). The adjustment is achieved by loosening the lock nut see "Fig.2" and turning the adjustment screw see "Fig.2". The engine must be at top dead center on the compression stroke before any adjustments are made. This engine runs best with the valves set at a tight setting. If the valves are set too loose, power will be affected.

Fig2

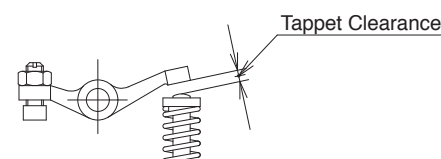

## Cam Gear Timing

If for some reason you have to disassemble your engine, please follow these important steps on reassembling the cam gear.

1. Remove the carburetor and back plate assembly. Notice the impression mark or dot opposite the rod journal on the crankshaft.
2. This mark is to point straight down or lined up with the outer case seam line at the bottom and hold crankshaft securely.
3. Reinstall the cam with the dot facing you. After you fully installing cam and then check dot should be pointing straight down will give you right timing.

## Operation of YS Super Mount (Option)

1. It is hold by 4 screws, 2 on the front ring and 2 on the rear soft mount. There are two different height of spacer we provide.
  - A set spacer (MN110S) : 10mm thickness
  - B set spacer (MN111S) : 4mm thickness
2. Please be sure not to hit any part of the fuselage by the engine after it installed.
3. If damper oil is leaked, refill TAMIYA damper silicon oil #600. Damper is a consumption parts, please exchange if you find worn or some defect.

## Cleaning

This engine is using silicon gaskets, "O" rings etc. Please use methanol or model engine fuel for cleaning. Do not use Kerosene, Gasoline, Machine oil, Automobile parts cleaner or house hold lubricants to clean. It will harm silicon parts.

## Engine Cooling

Be sure to secure cooling air for engine cooling. If it is not enough cooling air for the engine causes heat up the regulator and carburetor to make vaporized or percolates the fuel and will get deteriorations of engine performance or stop the engine. Please read carefully below for provision.

1. Please open air intakes and outlets as big as possible.
2. Take off cowling when you make long engine adjustment included idle adjustment. When air temperature is high, it may heat ups the regulator and carburetor to make vaporized or percolate the fuel even with out cowling. If it happens, wait till engine well cooling down before you restart and adjust.

## Rusting provision

Do not leave fuel in the engine after you finished for day. If you store the engine long period of time, few drops (about 1cc) of model engine lubricant oil from carburetor and clank several times. Do not use Automobile engine oil. They will not mix together with alcohol.

## Parts and Repair Service

If you can not find repair parts form hobby shops, you can order parts direct to our factory. We also do repair your engine at our factory. If you need repair service, please make detailed of states and send together with the engine.

## Warranty

We strictly inspect each process of production from parts to final assemble for keep good quality. If a performance deteriorates or part fails due to a manufacturing error under normal usage will repair no charge with in 1 year starting from the date of purchase. Warranty will not cover normal wear. Even with in 1 year warranty term, improper disassemble or assemble, under improper usage, any modification will avoid this warranty and there will be normal charge for parts and labors.

NO.	PART#	Name	QTY
1	YS7075	Crankcase	1
2	YS4495	Valve cover	1
3	YS0510	Head cover gasket	1
4	YS0515	Valve cover screw set	2
5	YS7080	Head gasket	1
	YS7085	Head assembly	
6	YS7090	Cylinder head	1
7	YS2160	Intake valve	1
8	YS2165	Exhaust valve	1
9	YS2170	Valve spring set	2
10	YS2175	Spring retainer set	2
11	YS2180	Valve spring retainer clips	4
12	YS0555	Rocker arm set	2
13	YS4510	Intake tappet adjusting screw	1
14	YS4515	Exhaust tappet Adjusting screw	1
15	YS0565	Tappet adjusting lock nuts	2
16	YS0570	Rocker arm shaft	1
17	YS0575	Rocker arm shaft screw	1
18	YS0580	E ring set	2
19	YS2615	Head bolt set	5
20	YS7095	Crankshaft	1
21	YS2190	C rankshaft ring	1
22	YS7100	Cylinder liner	1
23	YS7105	Piston	1
24	YS7110	Wrist pin	1
25	YS7115	Piston ring	1
26	YS6550	Connecting rod	1
27	YS6070	Back plate assy.	
28	YS0645	Back plate gasket	1
29	YS6075	Carburetor insulator	1
30	YS6080	Insulator gasket	1
31	YS4560	Back plate screw set	6
32	YS0655	Cam gear cover	1
33	YS0660	Cam gear cover O-ring	1
34	YS0665	Cam gear cover screws set	2
35	YS4565	Cam	1
36	YS6085	Cam followers	2
37	YS4580	Exhaust push rod	1
38	YS4585	Push rod cover	1
39	YS0690	Push rod cover O-ring	4
40	YS1050	Front bearing	1
41	YS1730	Front bearing oil seal	1
42	YS0701	Rear bearing	1
43	YS0705	Cam gear bearing set	2
	YS7120	Pump assembly	
44	YS7125	Regulator body	1
45	YS0195	Regulator adjusting screw	1
46	YS0725	Regulator adjusting screw O-ring	1
47	YS4605	Diaphragm	1
48	YS4610	Regulator spring	1
49	YS4615	Regulator screw set	2
50	YS5957	Fuel pump body with plunger	1
51	YS4625	Pump valve	2
52	YS5990	Pump valve spring	2
53	YS4635	Pump plate	1
54	YS4640	Pump screws	2
55	YS4645	Pump gasket	1
56	YS4655	Pump insulator	1
57	YS4660	Insulator O ring	1
58	YS4665	Pump bracket	1
59	YS4735	Upper push rod	1
60	YS4740	Lower push rod	1
61	YS6560	Pump cap	1

NO.	PART#	Name	QTY
	YS6565	Carburetor assembly	
62	YS6570	Carburetor body with throttle	1
	YS2740	Needle valve assembly	
63	YS2690	High speed needle valve	1
64	YS2695	High speed needle valve O-ring	1
65	YS2700	High speed needle seat	1
66	YS2705	Needle valve socket O-ring set	3
67	YS2710	Needle valve detent	1
68	YS4755	Throttle barrel seal	1
69	YS1090	Throttle barrel retainer	1
70	YS0785	Throttle stop screw	1
71	YS0790	Throttle stop spring	1
72	YS0200	Throttle arm set	1
73	YS4760	Carburetor gasket	1
74	YS2715	Drive washer	1
75	YS2720	Drive washer retainer	1
76	YS6000	Intake pipe	1
77	YS0840	Intake pipe O-ring	4
78	YS7130	Wrist pin access plug	1
79	YS0825	Propeller washer	1
80	YS6145	Propeller nut set	2
81	YS4723	Wrist pin access screw	1
82	YS5130	Check valve	1
	YS6100	Gasket set	4
	YS6573	O ring set	15
	YS4720	Fuel tank clunk	1
	YS5970	Tube holder	1
	YS6130	Ignition plug	1
	YS6110	Ignition box 2	1

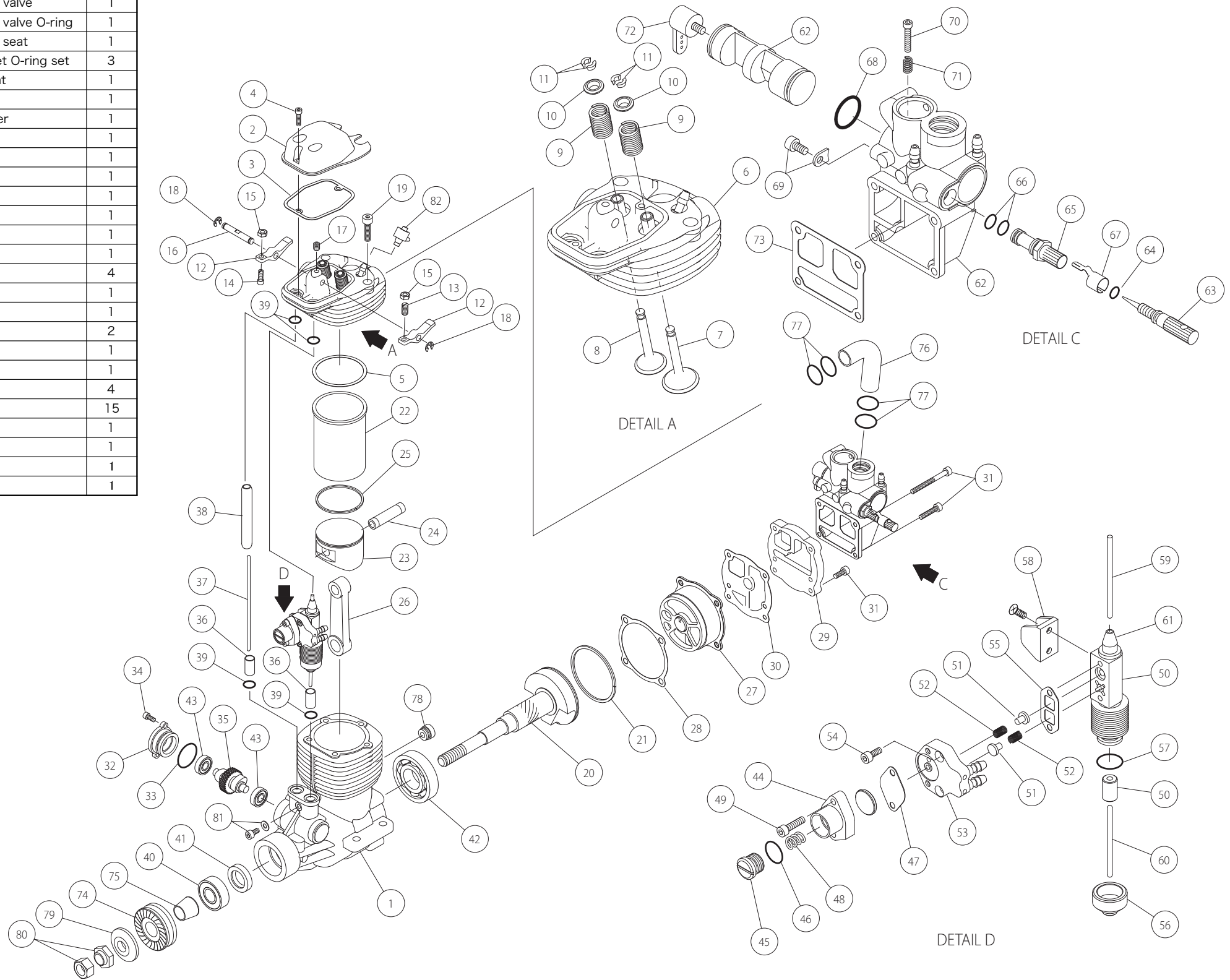

### YS Parts and Service

1370 PORTER DRIVE MINDEN NEVADA 89423

Phone: 775-267-9252 Fax: 775-267-9690