

OPERATOR'S MANUAL

DZ170 (Parts No. YS0089)

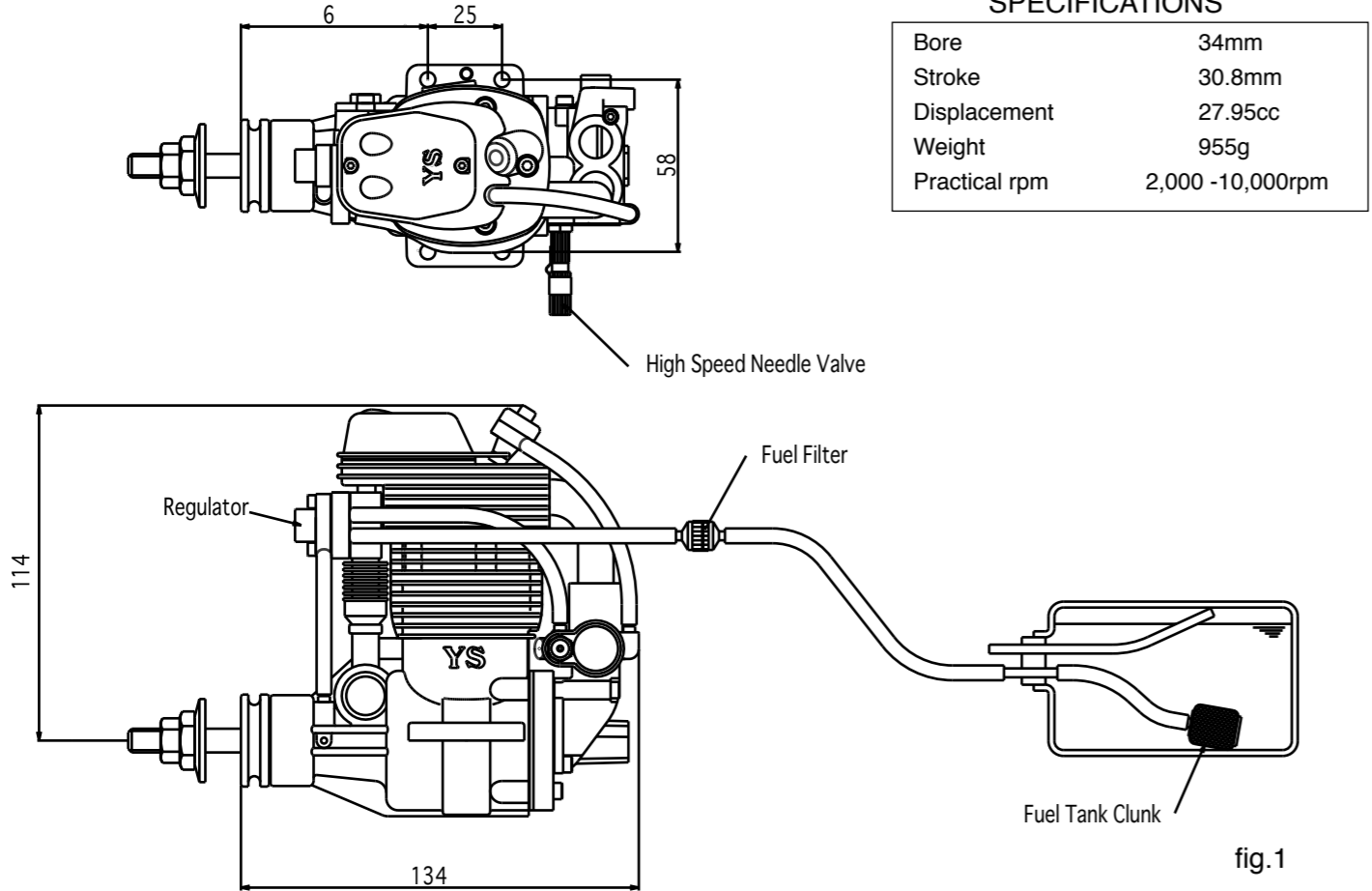

SPECIFICATIONS	
Bore	34mm
Stroke	30.8mm
Displacement	27.95cc
Weight	955g
Practical rpm	2,000 -10,000rpm

START UP

- 1 Always break the fuel line between the fuel filter and the tank for filling. This will help to prevent dirt from entering the fuel pump. To prevent flooding the engine, clamp the fuel line with a hemostat or clip where it enters the fuel pump.
- 2 Open the high speed needle 2 turns from the closed position. The engine should run very rich with the recommended fuel and glow plug. We recommend YS 20/20 fuel (20% nitro / 20% oil) which is available from several manufacturers.
- 3 An electric starter is mandatory for starting this engine. Attempting to hand start this engine is difficult and dangerous.
- 4 Close the throttle to the idle position and connect the glow driver. The engine is now ready for starting.

DO NOT ATTEMPT TO START ENGINE AT FULL THROTTLE AS THIS IS VERY DANGEROUS. ALWAYS USE EXTREME CAUTION WHEN ENGINE IS RUNNING.

BREAK-IN

To maximize engine performance and increase durability, please follow this break-in procedure.

- 1 Use the same size (or slightly smaller) propeller than you intend to use in flying.
- 2 Use a good quality fuel containing 15% to 30% nitro, and oil content of 20% to 24%. Synthetic oil only. If you use castor oil, no more than 2% is recommended.
DO NOT USE FOUR CYCLE FUEL DUE TO LOW OIL CONTENT.
- 3 After the engine has started, slowly bring the throttle up to full. Set high speed needle so it is running at a good rich setting with out the glow driver.
- 4 After the initial 20 minute break-in, mount the engine in the aircraft and set the high speed to a richer than normal setting for the first 10 flights. This will help to lubricate all moving parts.

HIGH SPEED NEEDLE ADJUSTMENT

- 1 Adjustment of the high speed is done by the carburetor needle valve. When the needle valve is turned clockwise, the mixture is leaner. When it is turned counter-clockwise, the mixture is richer. A good starting position for the high speed needle valve is 2 turns open from the fully closed position. At this setting the engine will be very rich and may die when you remove the glow driver. If this happens, turn the needle valve in 1/2 turn and try again. The final running setting for the high speed needle will be approximately 1 to 1-1/2 turns open from fully closed.
- 2 When the engine is started, open the throttle gradually. Next, find the peak position (highest RPM) by adjusting the needle valve. Then the needle valve should be opened approximately 1/8 - 1/4 turns from full RPM to achieve best performance.

REGULATOR ADJUSTING

DO NOT ATTEMPT TO ADJUST THE REGULATOR SCREW WITH THE ENGINE RUNNING. STOP THE ENGINE BEFORE ADJUSTING THIS SCREW

The low speed adjustment is the regulator screw on the front of the engine. Turning the screw clockwise will richen the idle mixture, and counter-clockwise will lean the idle mixture. It is preset at the factory but may require further adjustment depending on fuel and conditions in your areas.

- 1 Wait until the engine is up to operating temperature before adjusting the idle mixture.
- 2 Close the throttle gradually to an idle (approximately 2,200 rpm). Let it idle for 15 -20 seconds and then slowly advance the throttle. The adjustment is correct when low to high speed has a smooth transition.

- 3 If the engine is running rough at idle or too rich, turn the regulator adjustment counter-clockwise to lean out the low end.
- 4 If the engine speeds up at idle, the low speed mixture is too lean. Turn the low speed regulator adjustment clockwise to richen the mixture.

fig.3

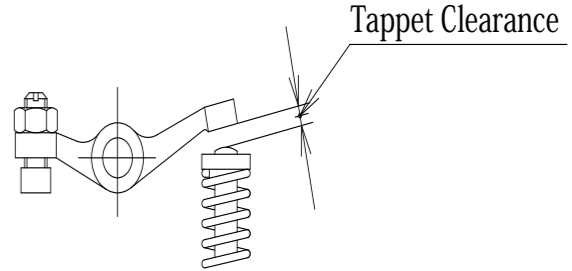

TAPPET ADJUSTMENT

Tappet clearance is preset at the factory. Adjustment, if you needed, should be checked after the initial break-in. For maximum performance, valves should be checked as normal maintenance.

- 1 Clearance adjustment should be done when the engine is cool.
- 2 The proper clearance should be set at not more than 0.002" maximum. The adjustment is achieved by loosening the lock nut (fig.3) and turning the adjustment screw. The engine must be at top dead center on the compression stroke before any adjustments are made. This engine runs best with the valves set at a tight setting. If the valves are set too loose ,power will be affected.

CAM GEAR TIMING

If for some reason you have to disassemble your engine, please follow these important steps on reassembling the cam gear.

- 1 Remove the carburetor and backplate assembly. Notice the impression mark or dot opposite the rod journal on the crankshaft. This mark is to point straight down or lined up with the outer case seam line at the bottom.
- 2 Reinstall the cam with the dot facing you and pointing slightly to the left. This will allow the cam to turn to the right when properly installed. The dot should be pointing straight up when cam is fully installed. Reinstall cam cover and timing is now set.

FUEL PUMP

If you must disassemble the fuel pump to change the diaphragm or to clean, take care that the valves and springs are replaced in exactly the same manner in which they were removed. Do not disassemble the pump needlessly. Use care with filtering your fuel and keeping the entire fuel system in good working order. It will help to prevent fuel pump problems.

FEATURES

The DZ170 was developed for serious aerobatics competition and large IMAC style aircraft. It differs from previous YS Engines in that it does not use a high pressure fuel system but rather a true fuel pump.

- *Crankcase supercharging system unique to YS 4 stroke engines
- *Fuel injected
- *Convenient fuel pump adjustment
- *High horsepower output with long service life

GLOW PLUG

Select the most appropriate glow plug from those designed specifically for 4 cycle engines. Glow plug selection greatly affects the maximum engine output and low idle. If RPM's decrease or stop when the booster cord is removed, replace the plug. We recommend the YS#4 plug for maximum performance. These are available from YS Parts & Service or your favorite dealer.

INSTALLATION

WE RECOMMEND THAT THIS ENGINE BE MOUNTED ON A SHOCK ABSORBING SOFT MOUNT

- 1 Connect the engine to the tank as shown in fig.1. The recommended fuel tank size is 18 to 24 oz. A standard clunk type fuel tank may be used. If this type of tank is used, you must use the special clunk supplied with the engine. Please note that with this clunk, all of the fuel cannot be used from the tank. As soon as any part of the clunk becomes exposed, the engine will stop due to air entering the fuel pump.
- 2 Always use a fuel filter. We recommend YS filter (YS1195). With this filter, you must remove the cloth portion of the filter and leave both the metal filter screens in place.

PROPELLER INSTALLATION

Due to the high output power of the DZ170 engine, it is supplied with a double locknut system for added safety. If you use any other type of spinner or prop nut device, make sure it is of the double nut type.

- 1 Mount the propeller and tighten the rear nut. Next, tighten the front nut as shown in fig.2. The rear nut has an offset shoulder so the front nut will secure itself to the rear nut.
- 2 Select a good quality propeller that will allow the engine to run at maximum speed between 7,800 to 8,800 rpm range. We recommend sizes 17X13 to 18X11. Other prop sizes may be used as long as the correct rpm range.

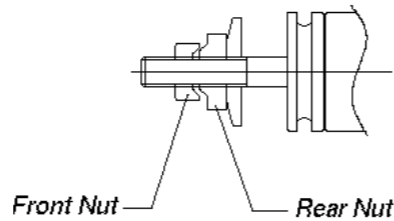
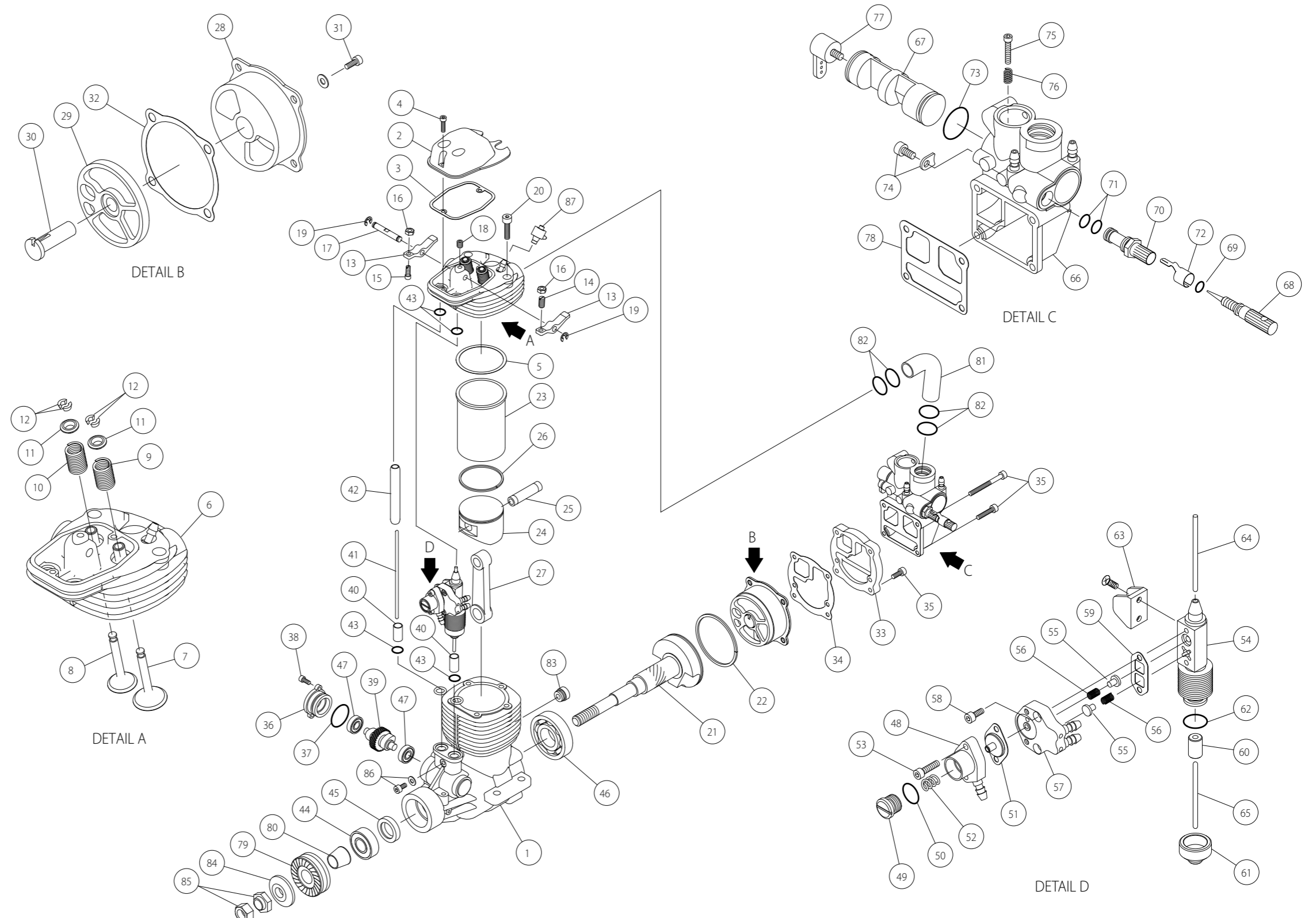

fig.2

DZ170 Parts list

#	Part#	Description	QTY
1	YS5900	Crankcase	1
2	YS4495	Valve cover	1
3	YS0510	Head cover gasket	1
4	YS0515	Valve cover screw set	2
5	YS5905	Head gasket	1
6	YS5910	Head assembly	1
7	YS4505	Cylinder head	1
8	YS2160	Intake valve	1
9	YS2165	Exhaust valve	1
9	YS5915	Exhaust valve spring	1
10	YS5920	Intake valve spring	1
11	YS2175	Spring retainer set	2
12	YS2180	Valve spring retainer clips	4
13	YS0555	Rocker arm set	2
14	YS4510	Intake tappet adjusting screw	1
15	YS4515	Exhaust tappet Adjusting screw	1
16	YS0565	Tappet adjusting lock nuts	2
17	YS0570	Rocker arm shaft	1
18	YS0575	Rocker arm shaft screw	1
19	YS0580	E ring set	2
20	YS2615	Head bolt set	5
21	YS5925	Crankshaft	1
22	YS2190	Crankshaft ring	1
23	YS5930	Cylinder liner	1
24	YS5935	Piston	1
25	YS5940	Wrist pin	1
26	YS5125	Piston ring	1
27	YS5945	Connecting rod	1
28	YS5980	Back plate assy.	1
28		Back plate	1
29		Disc valve	1
30		Disc valve pin	1
31		Disc valve screw	1
32	YS0645	Back plate gasket	1
33	YS4550	Carburetor insulator	1
34	YS4705	Insulator gasket	1
35	YS4560	Back plate screw set	6
36	YS0655	Cam gear cover	1
37	YS0660	Cam gear cover O-ring	1
38	YS0665	Cam gear cover screws set	2
39	YS4565	Cam	1
40	YS5985	Cam followers	2
41	YS4580	Exhaust push rod	1
42	YS4585	Push rod cover	1
43	YS0690	Push rod cover O-ring	4
44	YS1050	Front bearing	1
45	YS1730	Front bearing oil seal	1
46	YS0701	Rear bearing	1
47	YS0705	Cam gear bearing set	2
48	YS5950	Pump assembly	1
48		Regulator body	1
49	YS0195	Regulator adjusting screw	1
50	YS0725	Regulator adjusting screw O-ring	1
51	YS4605	Diaphragm	1
52	YS4610	Regulator spring	1
53	YS4615	Regulator screw set	2
54		Fuel pump body	1
55	YS4625	Pump valve	2
56	YS5990	Pump valve spring	2
57		Pump plate	1
58	YS4640	Pump screws	2
59	YS4645	Pump gasket	1
60		Plunger	1
61	YS4655	Pump insulator	1



62	YS4660	Insulator O ring	1
63	YS4665	Pump bracket	1
64	YS4735	Upper push rod	1
65	YS4740	Lower push rod	1
	YS4745	Carburetor assembly	1
66	YS4750	Carburetor body with throttle barrel	1
67		Throttle barrel	1
	YS2740	Needle valve assembly	1
68	YS2690	High speed needle valve	1
69	YS2695	High speed needle valve O-ring	1
70	YS2700	High speed needle seat	1
71	YS2705	Needle valve socket O-ring set	2
72	YS2710	Needle valve detent	1
73	YS4755	Throttle barrel seal	1
74	YS1090	Throttle barrel retainer	1
75	YS0785	Throttle stop screw	1

76	YS0790	Throttle stop spring	1
77	YS0200	Throttle arm set	1
78	YS4760	Carburetor gasket	1
79	YS2715	Drive washer	1
80	YS2720	Drive washer retainer	1
81	YS6000	Intake pipe	1
82	YS0840	Intake pipe O-ring	4
83	YS1540	Wrist pin access plug	1
84	YS0825	Propeller washer	1
85	YS6145	Propeller nut set HEX13mm	2
86	YS4723	Wrist pin access screw	1
87	YS5130	Check valve	1
	YS4710	Gasket set	4
	YS4715	O ring set	14
	YS4720	Fuel tank clunk	1
	YS5970	Tube holder	1

YS Parts and Service

1370 PORTER DRIVE MINDEN NEVADA 89423
 Phone: 775-267-9252 Fax: 775-267-9690